

RF Over Fiber Analog/Digital Link 6GHz

(5MHz to 6GHz, SM28 Fiber)



DATASHEET

BUY NOW



Features

- Up to 6GHz
- SM28 Fiber
- Low Loss
- Low Cost
- Stable

Applications

- GSM Repeater
- CDMA Repeater
- WCDMA Repeater
- PHS Repeater
- Digital TV Repeater
- Broadcast Repeater

The RFOF is designed to form an RF link between two points using fiber optical cables. It features immunity to interferences, high bandwidth, low signal loss over long distances, low signal distortion, low power consumption, high reliability, and is easy to implement. It converts an input RF electrical signal into an optical signal via a high linearity DFB laser (transmitter) and re-converts the optical signal back into the RF signal at the other end of the fiber link via a high linearity photodiode integrated with low noise amplifier (receiver). The transmitter and receiver pair form a transceiver that provides a transparent data transmission channel. They are available in 1310nm and 1550nm wavelengths, providing a versatile wavelength division multiplexing (WDM) capability. For example, bidirectional RF communication can be established with a single fiber link using two different wavelength transceivers and matching WDM cable adaptors. Another example is that three channels can be transmitted through a single fiber link by combining three transceivers of different wavelengths with our WDM cable adaptors. The module is packaged in a rack mount box or ruggedized outdoor aluminum case. Temperature compensation is built into the transmitter.

The RFOF modules are suitable for telecommunications, satellites, radio telescopes, distribution antennas, broadcasting audio and video, and timing synchronization. For example, point-to-point antennas can be connected from several meters to many kilometers away from the control room by fiber cables; Base stations can be connected through fiber to remote sector antennas; Satellite antennas can be connected through fiber cable to remote sites by RF over Fiber solutions.

A pair of transmitter and receiver of the same wavelength is needed to form an RF link over a fiber. Two pairs of transmitter and receiver are needed to form a bidirectional RF link over a single fiber, in which either WDM fiber patch cables (1550nm and 1310nm) or circulator fiber patch cables (same wavelength) are used. We supply these 3-port cables that directly plug into the transmitters, receivers, and transmitting fiber line.

Specifications

Parameter	Min	Typical	Max	Unit
Optical Wavelength	1310 ± 20		1550 ± 20	nm
Optical Output Power	0			dBm
Optical Input Power	-16		-6	dBm
RF Frequency Range	0.005		6	GHz
Gain Flatness (p-p)			± 3	dB
RF Output Power	-30		-10	dBm
Input RF Return Loss		18		dB
RF Input Power			10	dBm
Spurious Free Dynamic Range	100			dBm/H ^{2/3}
Noise Floor			-120	dBm/Hz
Transmit Gain Control (AGC)				
Receive Gain Control (AGC)				
Link Gain	0			dB
CNR	35			dB
Fiber Type		SM28		
Fiber Connector Type		SC/APC		
RF Impedance		50		Ω
RF Connector		BNC		
Power Consumption	3			W
Weight	0.5			kg
Operating Temperature	-20		50	°C
Storage Temperature	-45		85	°C

Note: The specifications provided are for general applications with a cost-effective approach. If you need to narrow or expand the tolerance, coverage, limit, or qualifications, please [\[click this link\]](#):

Legal notices: All product information is believed to be accurate and is subject to change without notice. Information contained herein shall legally bind Agiltron only if it is specifically incorporated into the terms and conditions of a sales agreement. Some specific combinations of options may not be available. The user assumes all risks and liability whatsoever in connection with the use of a product or its application.

Rev 08/28/24

© Photonwares Corporation

P +1 781-935-1200

E sales@photonwares.com

W www.agiltron.com

Information contained herein is deemed to be reliable and accurate as of the issue date. Photonwares reserves the right to change the design or specifications at any time without notice. Agiltron is a registered trademark of Photonwares Corporation in the U.S. and other countries.

RF Over Fiber Analog/Digital Link 6GHz

(5MHz to 6GHz, SM28 Fiber)



DATASHEET

Dimensions (Unit: mm)

TX Module

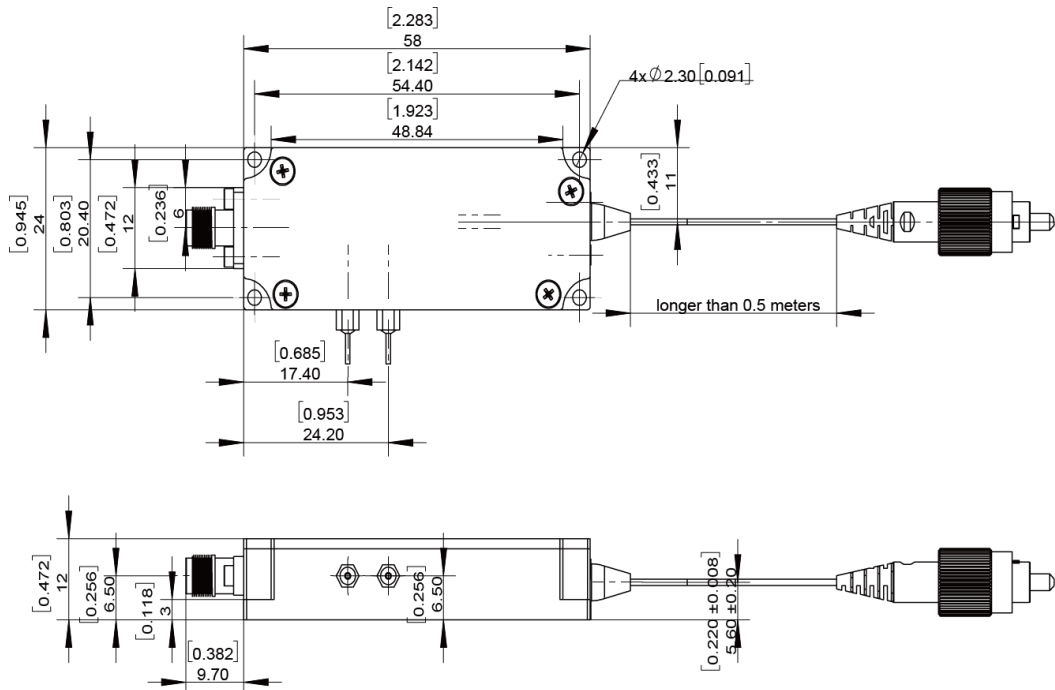

RX Module

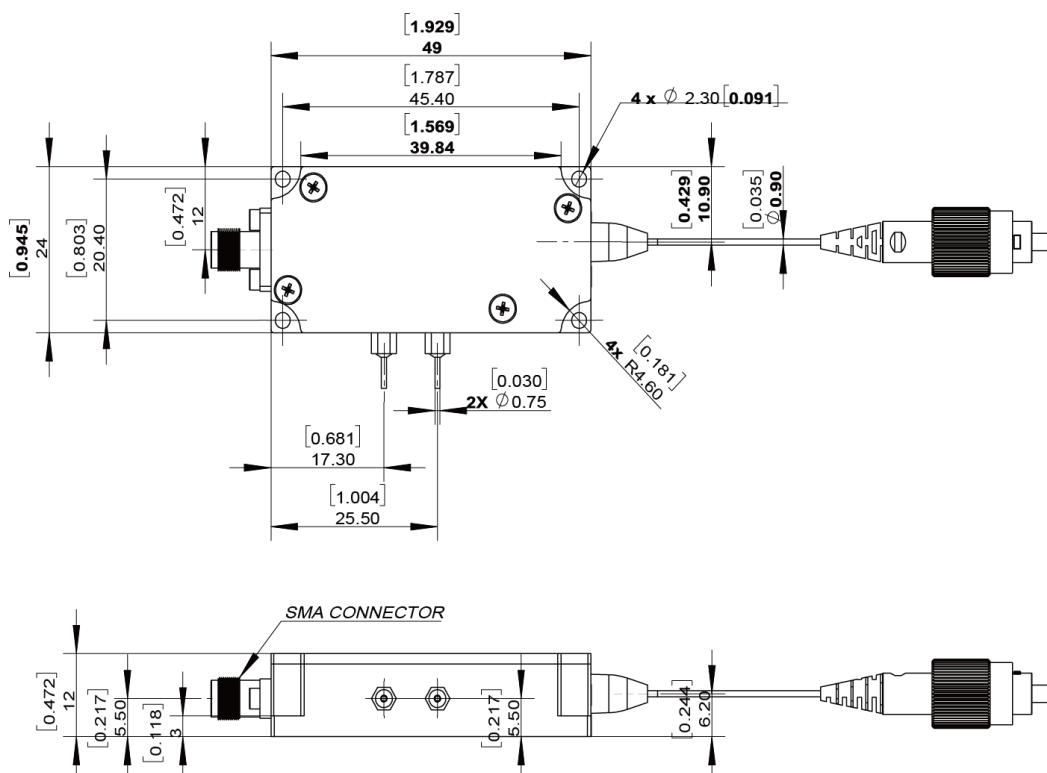

*Product dimensions may change without notice. This is sometimes required for non-standard specifications.

RF Over Fiber Analog/Digital Link 6GHz

(5MHz to 6GHz, SM28 Fiber)



DATASHEET |

Electrical/Computer Connection

RF Over Fiber Analog/Digital Link 6GHz

(5MHz to 6GHz, SM28 Fiber)



DATASHEET

Ordering Information

Prefix	RF Frequency	Wavelength	TX/RX	Package	Bidirectional ^[2]	Fiber Connector	RF Connector
RFOF-	6GHz = 06G Special = 000	1550 nm = 1 1310 nm = 3 1490 nm = 4 Special = 0	Receiver = 1 Transmitter = 2 Pair ^[1] = 3	Module = 1 Rack = 2 Special = 0	None = 1 Yes = 2 Special = 0	FC/APC = 2 FC/UPC = 3 SC/APC = 4 SC/UPC = 5 LC/APC = A LC/UPC = U Special = 0	SMA = 1 Special = 0

Note:

[1]. Pair = Receiver + Transmitter

[2]. Bidirectional means two-way communications via a single fiber link. The price is double since it comprises two pairs of transceivers and receivers with WDM (different wavelength) or circulator (same wavelength) cable jumpers.

Red marked -- Special order

Application Notes

Fiber Core Alignment

Note that the minimum attenuation for these devices depends on excellent core-to-core alignment when the connectors are mated. This is crucial for shorter wavelengths with smaller fiber core diameters that can increase the loss of many decibels above the specification if they are not perfectly aligned. Different vendors' connectors may not mate well with each other, especially for angled APC.

Fiber Cleanliness

Fibers with smaller core diameters (<5 μm) must be kept extremely clean, contamination at fiber-fiber interfaces, combined with the high optical power density, can lead to significant optical damage. This type of damage usually requires re-polishing or replacement of the connector.

Maximum Optical Input Power

Due to their small fiber core diameters for short wavelength and high photon energies, the damage thresholds for device is substantially reduced than the common 1550nm fiber. To avoid damage to the exposed fiber end faces and internal components, the optical input power should never exceed 20 mW for wavelengths shorter 650nm. We produce a special version to increase the how handling by expanding the core side at the fiber ends.

RF Over Fiber Analog/Digital Link 6GHz

(5MHz to 6GHz, SM28 Fiber)



DATASHEET

Typical Response

■ S11

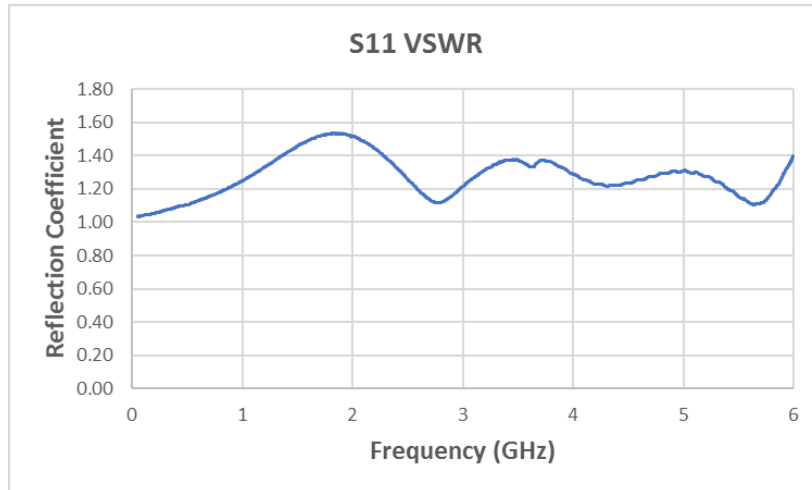

■ S22

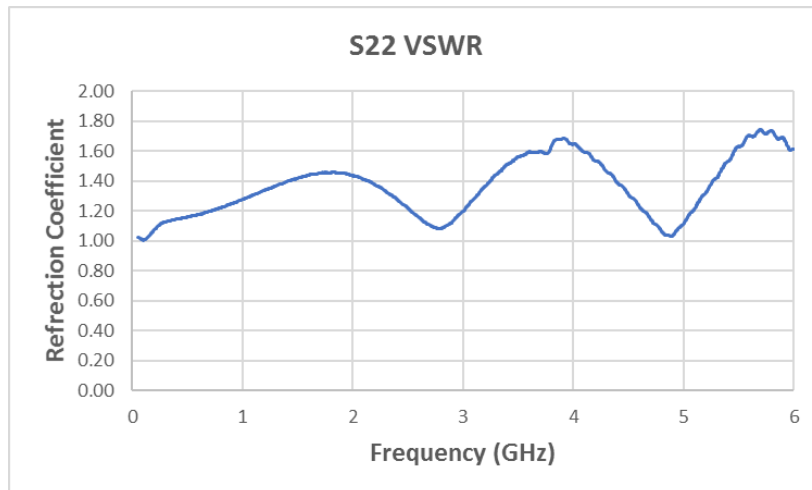

■ S21

